

# WATER COOLED CENTRIFUGAL CHILLER

Product Data Catalog



**MODELS**  
**MS80T-W**



**MULTISTACK**

***The Leader in Modular Chillers***



## MULTISTACK WATER COOLED CENTRIFUGAL CHILLER MODULES

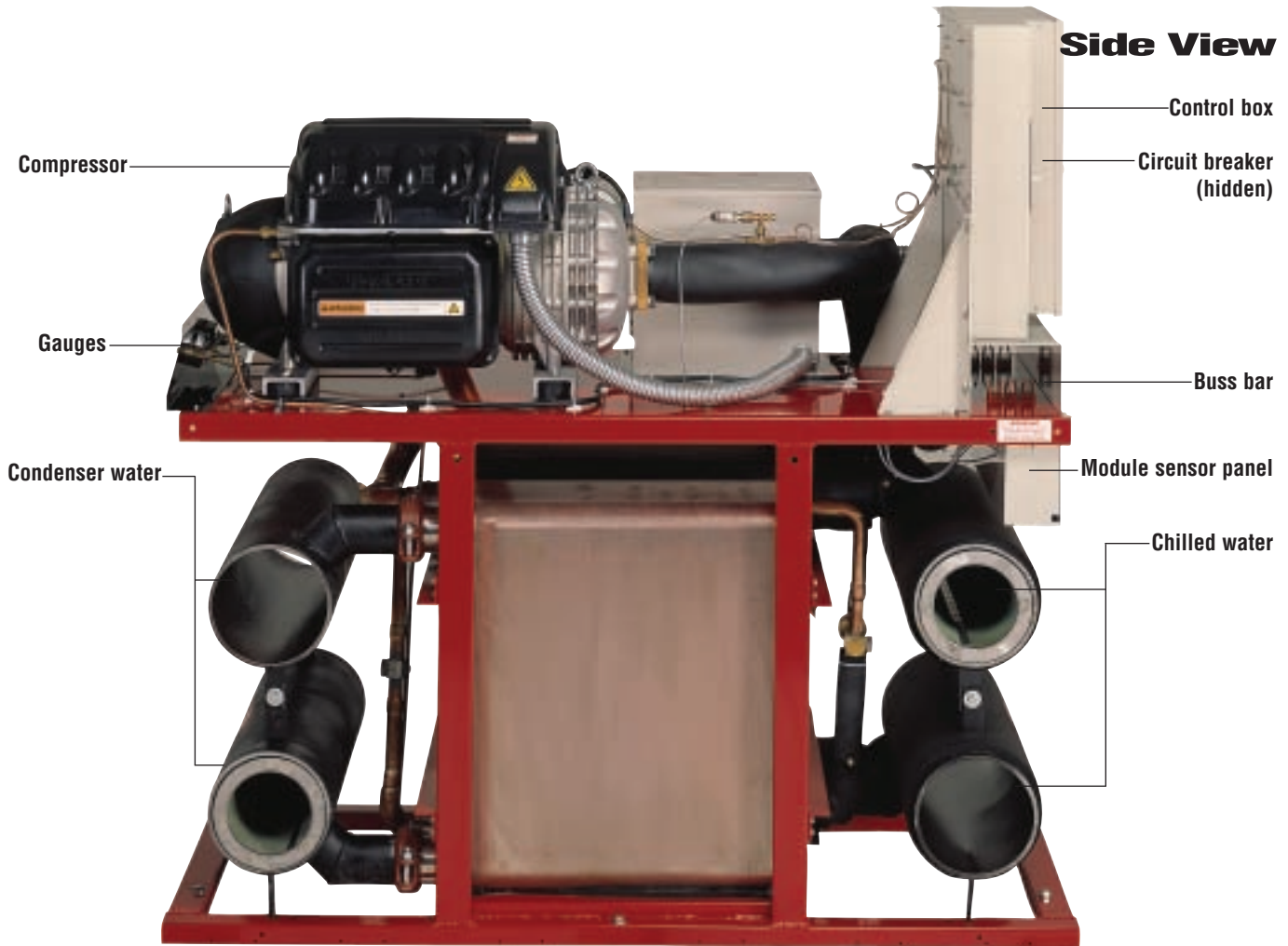

### **Cutting Edge Compressor Technology**

- MagLev™ magnetic bearings; no metal-to-metal contact
- Quieter than typical background noise
- Soft start; pulls only 2 amps at 460V
- Oil Free design
- Superior part load efficiency
- Integrated VFD control
- Uses environmentally friendly R-134A refrigerant

### **Superior Dependability**

- Multiple independent systems for redundancy
- Comprehensive computer monitoring
- Automatic lead-lag
- Automatic fault recording

### **Easy Installation**

- Compact modules fit through most doorways and into freight elevators
- Modules connect quickly and easily
- Factory charged and run tested
- Micro refrigerant charge compliant with ASHRAE 15 in most cases

### **High Flexibility**

- Service can be performed on a convenient, non-emergency basis
- Install only the capacity required at the time
- Operates only the capacity required by the load
- Integrates fully with building management through BACnet®, ModBus®, N2, or LON.

## General Data Table

MODEL	MS80
<b>Compressor Type</b>	MagLev™ Centrifugal
Dry weight (lbs. each)	265
Normal capacity (each)	80 tons
Quantity	1
Oil charge (pints)	n/a
<b>Evaporator</b>	Brazed Plate
Weight (lbs. each)	417
Water storage (gallons each)	11.5
Quantity	1
Header system (gallons)	15.1
<b>Condenser</b>	Brazed Plate
Weight (lbs. each)	484
Water storage (gallons each)	12.6
Quantity	1
Header system (gallons)	15.1
Refrigerant type	R-134A
Refrigerant charge (lbs./circuit)	45
Number of circuits	1
Operating weights (lbs.)	2,651
Shipping weight (lbs.)	2,195

## Performance Table

**All performance at 80 tons net capacity**

SINGLE MODULE		MS80T1														
		ENTERING CONDENSER WATER TEMPERATURE														
		75°			80°F			85°F			90°F			95°F		
Leaving Chilled Water °F	RPM X 1000	Input kW	EER	RPM X 1000	Input kW	EER	RPM X 1000	Input kW	EER	RPM X 1000	Input kW	EER	RPM X 1000	Input kW	EER	
50°F	30.9	40.8	23.53	31.7	44.7	21.48	32.4	48.9	19.63	33.2	53.4	17.98	34.0	58.3	16.47	
48°F	31.5	42.5	22.59	32.2	46.4	20.69	33.0	50.7	18.93	33.8	55.4	17.33	34.6	60.4	15.89	
46°F	32.1	44.2	21.72	32.8	48.2	19.92	33.6	52.6	18.25	34.4	57.4	16.72	35.2	62.7	15.31	
45°F	32.4	45.1	21.29	33.1	49.1	19.55	33.9	53.6	17.91	34.7	58.5	16.41	35.5	63.9	15.02	
44°F	32.7	45.9	20.92	33.4	50.1	19.16	34.2	54.8	17.52	35.0	59.6	16.11	35.8	65.2	14.72	
42°F	33.3	47.8	20.08	34.1	52.1	18.43	34.9	56.9	16.87	35.7	62.1	15.46	36.6	68.0	14.12	
40°F	34.0	49.8	19.28	34.7	54.3	17.68	35.6	59.4	16.16	36.5	65.0	14.77	37.5	71.5	13.43	

Quoted capacity at all points is 80 tons. As long as compressor is not limited by demand or control parameters, it will adjust speed to meet demand provided the required operational point is on the compressor map. All performance data is based on a 10° F chilled water temperature drop through the evaporator and condenser. For total chiller performance, multiply outputs (Tons) and input (kW) by the number of modules. For selection procedures, see selection example. Modules are designed, tested, and rated in accordance with ARI 550-590.

**MULTISTACK WATER COOLED CENTRIFUGAL  
CAPACITY TABLES**

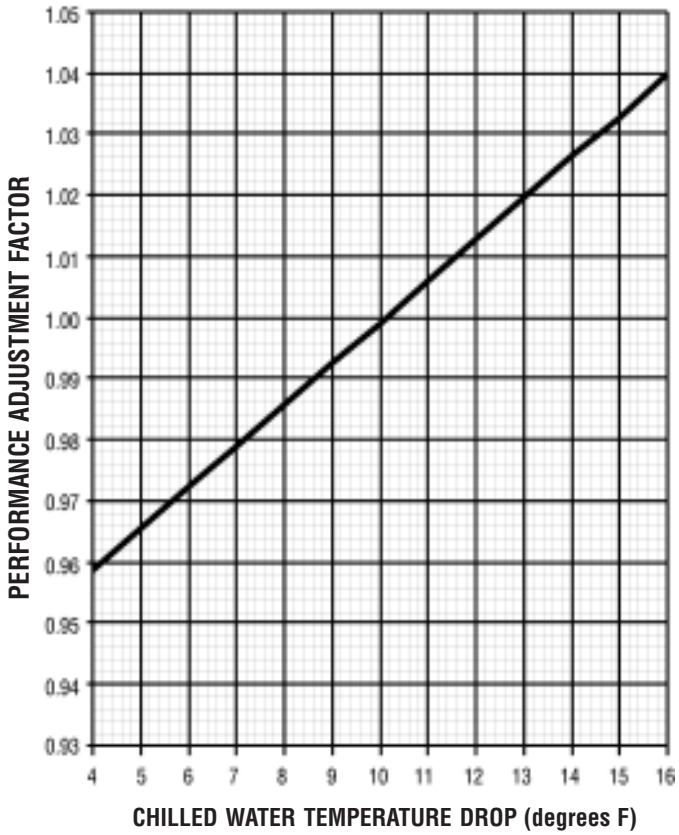

**Figure 1.** Performance Adjustment Factor

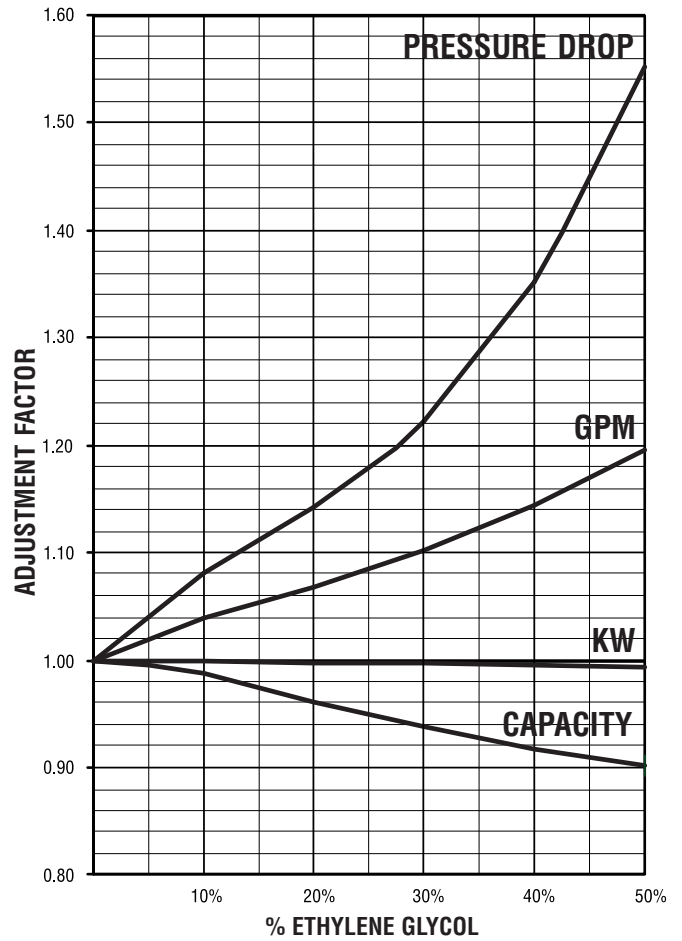

**Figure 3.** Ethylene Glycol Adjustment Factors

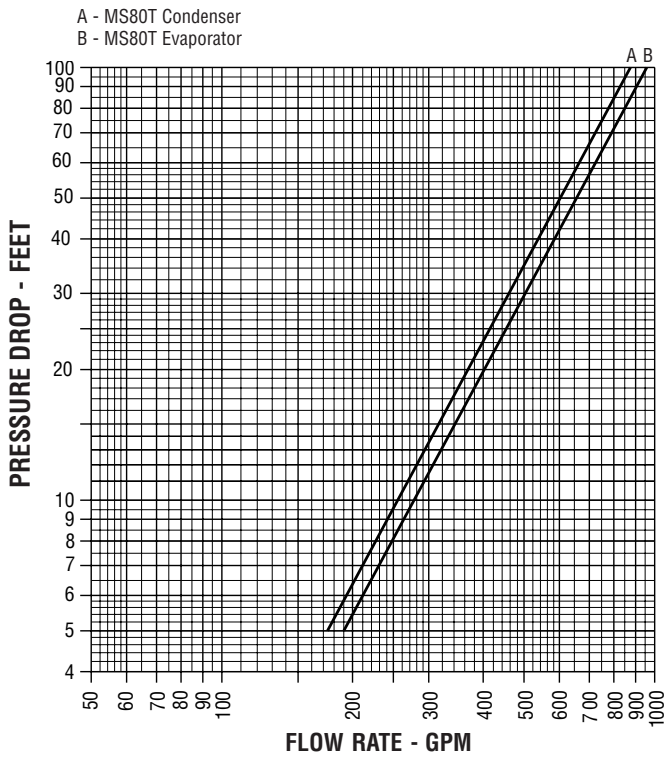

**Figure 2.** Water Pressure Drop

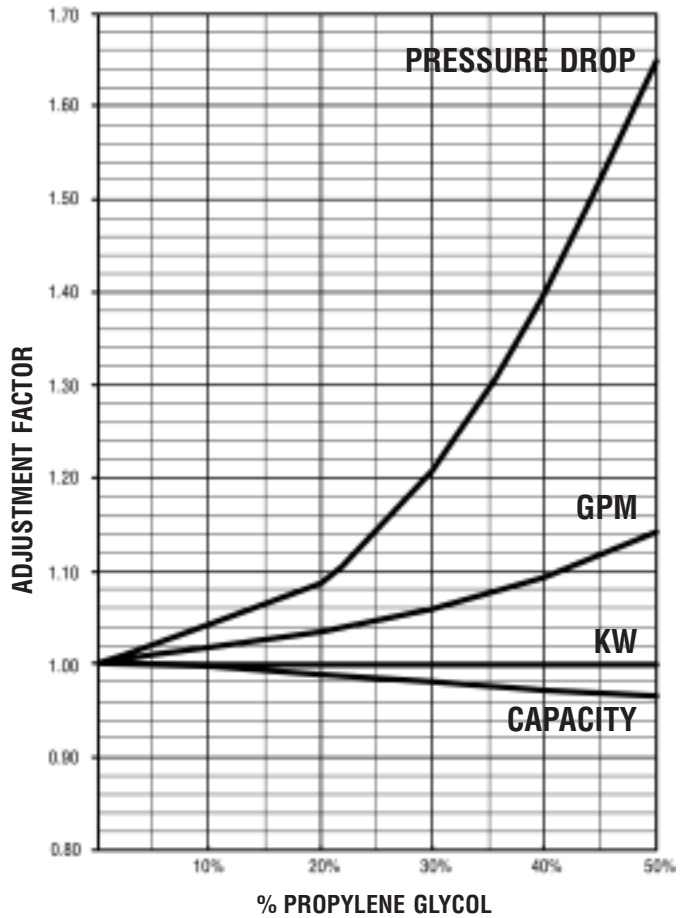

**Figure 4.** Propylene Glycol Adjustment Factors

## Selection

To select a MULTISTACK MS80T Centrifugal Water Cooled Chiller, the following information is requested:

1. Load in tons of refrigeration.
2. Chilled water temperature drop.
3. Leaving chilled water temperature.
4. Entering condenser water temperature.

## Capacity Tables

Capacity tables are based on a 10°F temperature drop through the evaporator and a capacity of 80 Tons at all chilled and condenser water temperatures. The module is optimized to provide 80 tons at the maximum efficiency. If the system load is less than 80 Tons, the chiller will unload to provide the smaller required capacity at a theoretically higher efficiency. For other than 10°F temperature drop, apply the respective performance adjustment factors from Figure 1 to determine the theoretical improvements resulting from a broader temperature difference.

## Water Flow Rates

Evaporator water flow can be determined as follows:

$$\text{GPM} = (24) (\text{Tons}) / \text{Temperature Drop } (^\circ\text{F})$$

Condenser water flow should always be determined using a 10°F temperature rise as follows:

$$\text{GPM} = 2.4 [\text{Tons} + (0.285)(\text{Compressor kW})]$$

## Waterside Pressure Drop

Evaporator and condenser waterside pressure drops are provided in Figure 2. To use Figure 2, divide the total water GPM by the number of modules in the chiller.

## Chilled Water Selection Example

System load = 450 tons. Chilled water drop of 12°F. Leaving water temperature of 45°F. Entering condensed water temperature of 85°F.

1. Use Figure 1 adjustment factor for tons to convert tons to 10°F at equivalent for use with capacity tables.  
 $\text{Tons} = 450 / 1.012 = 444.7 \text{ tons}$
2. Select the appropriate performance table based on module to be used. Read the Capacity and kW of a single module at the water temperature specified.  
 $\text{Capacity} = 80.0 \text{ tons}, \text{ kW} = 53.6$
3. To find the number of modules required, divide equivalent tons required at 10°F temperature drop by single module capacity from table:  
 $\text{Modules required} = 444.7 / 80 = 5.6 \text{ or } 6 \text{ modules}$   
 $\text{Chiller capacity} = (80.0)(6) = 480 \text{ tons}$   
 $\text{Power input} = (53.6)(6) = 321.6 \text{ kW}$
4. At 12°F evaporator temperature drop, applying Figure 1 performance adjustment factors result in:  
 $\text{Tons} = (480.0)(1.012) = 485.8 \text{ tons vs. system load}$
5. To determine evaporator and condenser water pressure drops, first determine GPM:  
 $\text{Evaporator GPM} = (24)(485.8) / 12 = 971.6 \text{ GPM}$   
 $\text{Condenser GPM} = 2.4[485.8 + (0.285)(321.6)] = 1385.9 \text{ GPM}$

6. With a six-module chiller, evaporator and condenser pressure drops are read from Figure 2 as follows:

$$\text{Evaporator} = \text{GPM} / \text{modules} = 971.6 / 6 = 162 \text{ GPM}$$

$$\text{Pressure drop} = 4.3 \text{ feet}$$

$$\text{Condenser} = \text{GPM} / \text{modules} = 1385.9 / 6 = 231 \text{ GPM}$$

$$\text{Pressure drop} = 7.2 \text{ feet}$$

*Note: The above calculations represent theoretical changes in performance based on well established empirical data. In reality, these calculated points may never be observed in operation since the MS80T will modulate to meet the required capacity and achieve its leaving chilled water setpoint.*

## Operation with Glycol

Ethylene glycol adjustment factors (Figure 3) should be used to adjust performance, depending on the percent of glycol used in the evaporator circuit. The factors in Table 3 are based on a 10°F change in fluid temperature through the evaporators.

Capacity and kW should be obtained by extrapolating no more than 10°F from the lowest leaving chilled water temperature shown in the capacity tables.

MULTISTACK should be contacted if leaving glycol temperatures below 40°F are required.

Adjustment factors for propylene glycol are shown in Figure 4 and are used in the same way given in the following example.

## Glycol Selection Example

Determine Capacity, GPM, Pressure Drop and kW for a MS80 module cooling 30% ethylene glycol from 50°F to 40°F, with an entering condensing temperature of 85°F and 100% water.

1. By extrapolating from the Performance Tables:  
 $\text{Capacity: } 80.0 \text{ tons}, \text{ kW: } 59.4$
2. Evaporator water flow and pressure drops are determined for water as in the previous example.  
 $\text{Evaporator GPM} = (24)(80) / 10 = 192 \text{ GPM}$   
 $\text{Evaporator pressure drop} = 6 \text{ feet}$
3. To convert performance for water to performance with ethylene glycol, read adjustment factors from Figure 3 at 30% glycol.  
 $\text{Capacity adjustment} \quad 0.94$   
 $\text{kW adjustment} \quad 0.99$   
 $\text{Evaporator GPM adjustment} \quad 1.10$   
 $\text{Pressure drop adjustment} \quad 1.22$
4. Calculate performance with 30% ethylene glycol by multiplying performance for water by adjustment factors:  
 $\text{Capacity} \quad 80.0 \times 0.94 = 75.2 \text{ tons}$   
 $\text{kW} \quad 59.4 \times 0.99 = 58.8 \text{ kW}$   
 $\text{GPM} \quad 192 \times 1.10 = 211.2 \text{ GPM}$   
 $\text{Pressure drop} \quad 6.0 \times 1.22 = 7.32 \text{ ft of water}$
5. To determine condenser water pressure drops, first determine GPM.  
 $\text{Condenser GPM} = 2.4[75.2 + (0.285)(59.4)] = 221 \text{ GPM}$
6. Condenser pressure drops are read from Figure 2 as follows:  
 $\text{Condenser pressure drop} = 6.5 \text{ feet}$

**MULTISTACK WATER COOLED CENTRIFUGAL CHILLER**

**End Elevation**

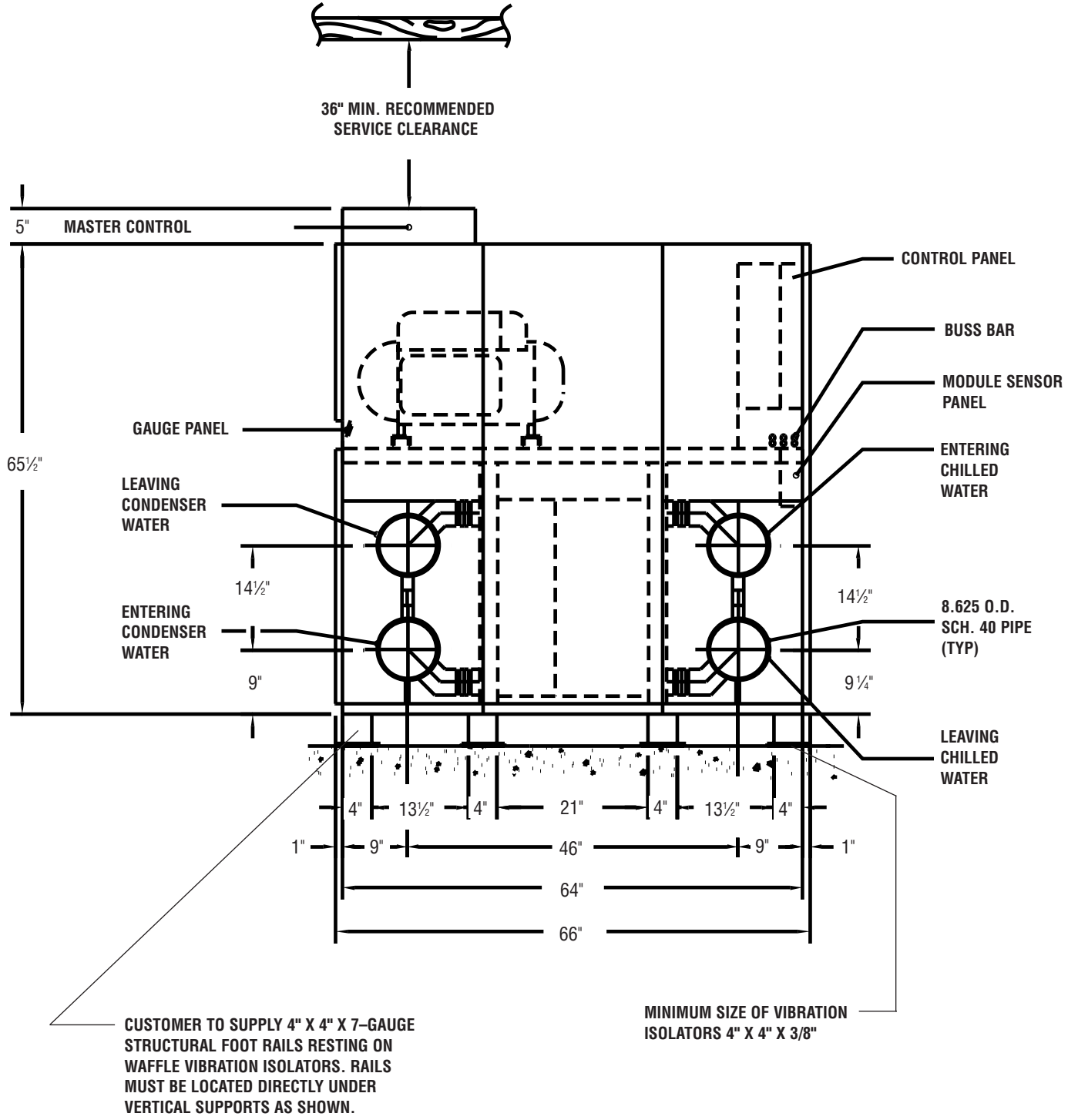

## External Input/Output Connections

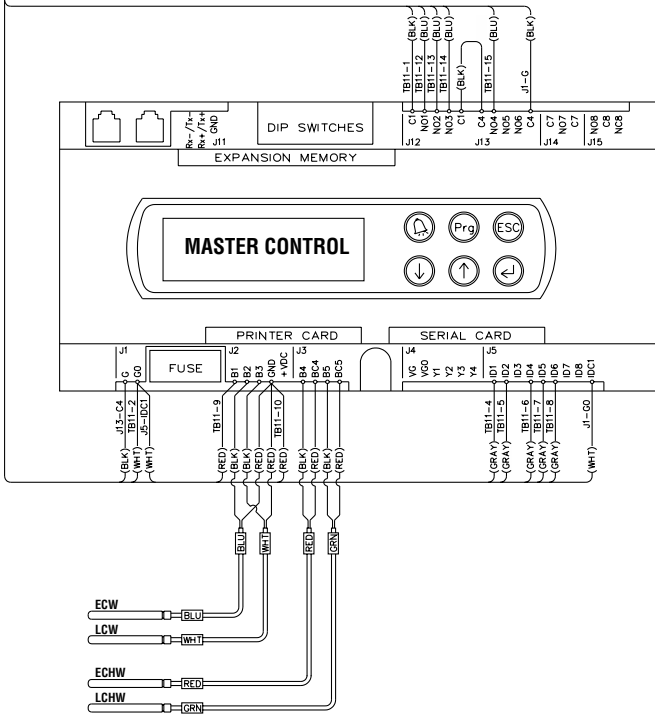
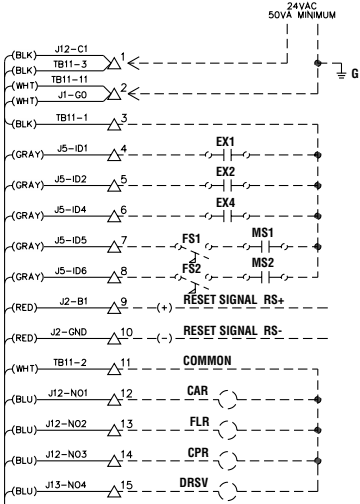

### LEGEND

- 1 ----- Components and wiring by others. (18 AWG Min. wire).
- 2 Inputs to terminals 4 through 8 of TB11 must be wired closed if not used.
- 3 External inputs (Closed to operate).
  - EX1 Manual reset required to resume operation.
  - EX2 Auto reset (Remote start/stop).
  - EX4 Auto reset (Power phase monitor input).
  - FS1 Flow switch (Chilled water).
  - FS2 Flow switch (Condenser water).
  - MS1 Aux. interlock (Chilled water pump starter).
  - MS2 Aux. interlock (Condenser water pump starter).
  - RS+ Reset signal (Software selectable 0-10VDC, 4-20mA).
  - RS- Reset signal (Software selectable 0-10VDC, 4-20mA).
- 4 External outputs.
  - CAR Customer alarm relay (24 VAC, 5 VA max).
  - CPR Condenser pump relay (24 VAC, 5 VA max).
  - FLR Full load relay (24 VAC, 5 VA max).
  - DRSV Debris removal solenoid valve (24 VAC, 6 W, 16VA)  
Max of (2) DRSV in this circuit.
- 5 Sensor Inputs
  - ECW Entering condenser water.
  - LCW Leaving condenser water.
  - ECHW Entering chilled water.
  - LCHW Leaving chilled water.

For additional information, see installation manual and master control user manual.

MCA	3 Conductor 1 Conduit	6 Conductor 2 Conduit
50	8	—
65	6	—
85	4	—
100	3	—
115	2	—
130	1	—
150	1/0	—
175	2/0	—
200	3/0	—
230	4/0	—
255	250 MCM	—
285	300 MCM	1/0
300	—	2/0
350	—	3/0
400	—	4/0
460	—	4/0
500	—	250 MCM

## System Wire & Fuse Sizing Specifications

Model No.	Volts/Hz/PH	Tons	Compressor	
			RLA	LRA
MS80T_H_W	460/60/3	80	96	132

### Wiring Sizing

(MCA = minimum circuit ampacity)

$$MCA = (1.25 \times RLA1^*) + RLA2 + RLA3$$

### Fuse Sizing

(MF = maximum fuse size)

$$MF = (2.25 \times RLA1^*) + RLA2 + RLA3$$

Where MF does not equal a standard size fuse, the next larger fuse should be used.

### Notes:

1. \*RLA1 = RLA of the largest motor in the system. RLA2 & RLA3 = RLA of other motors in the system.
2. Wire sizing is based on National Electrical Code (NEC) rating for 75°C wire, with 3 wires per conduit.
3. Wiring distance from branch circuit shall not exceed 100 feet.

**Required Chilled Water Piping**

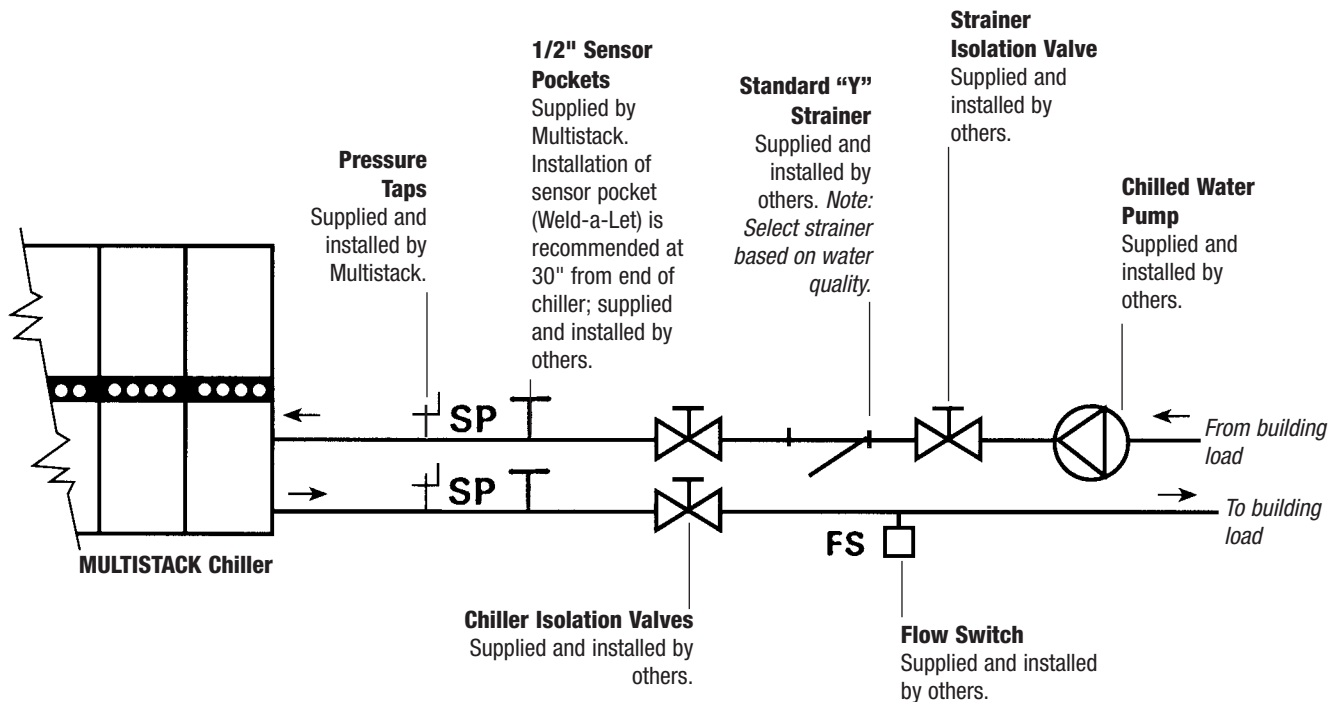

**Condenser Schematic with Head Pressure Control**

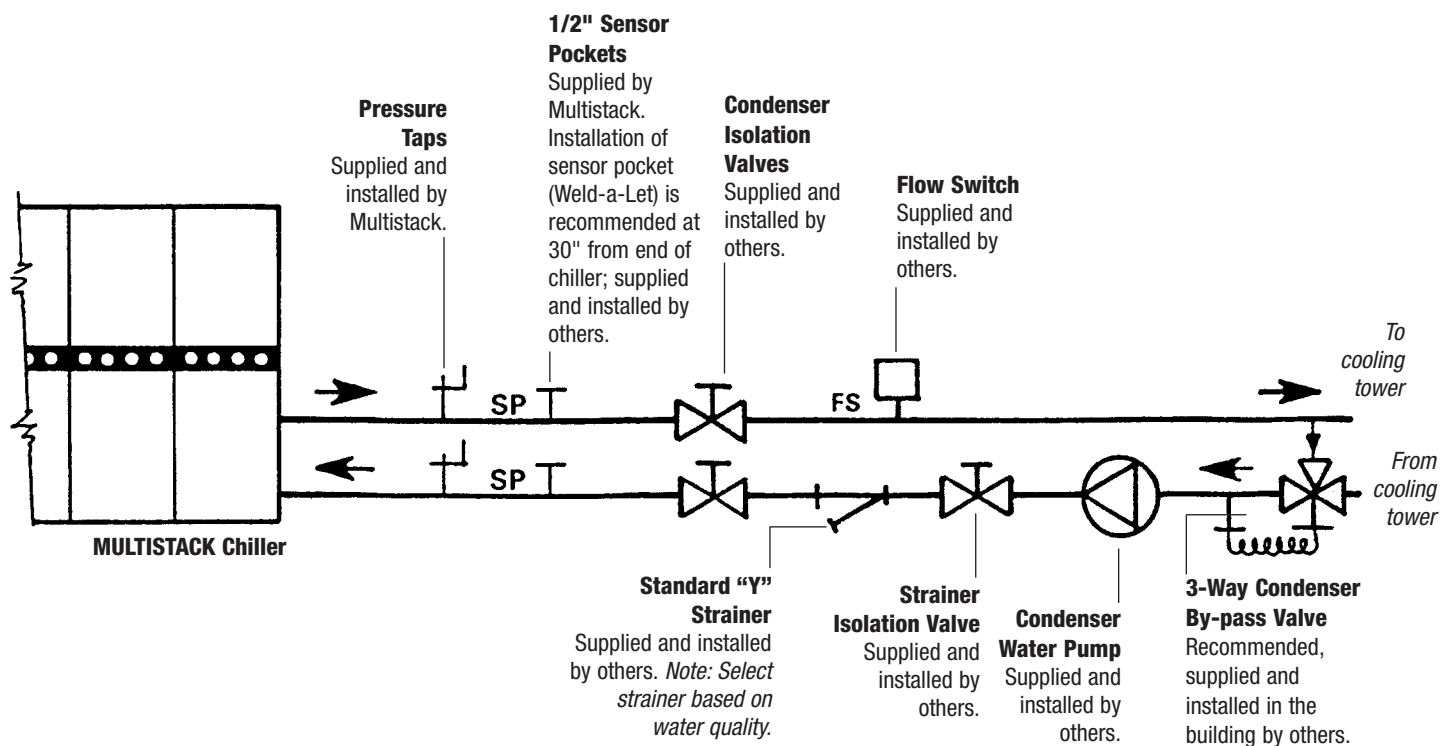

**Plan View**

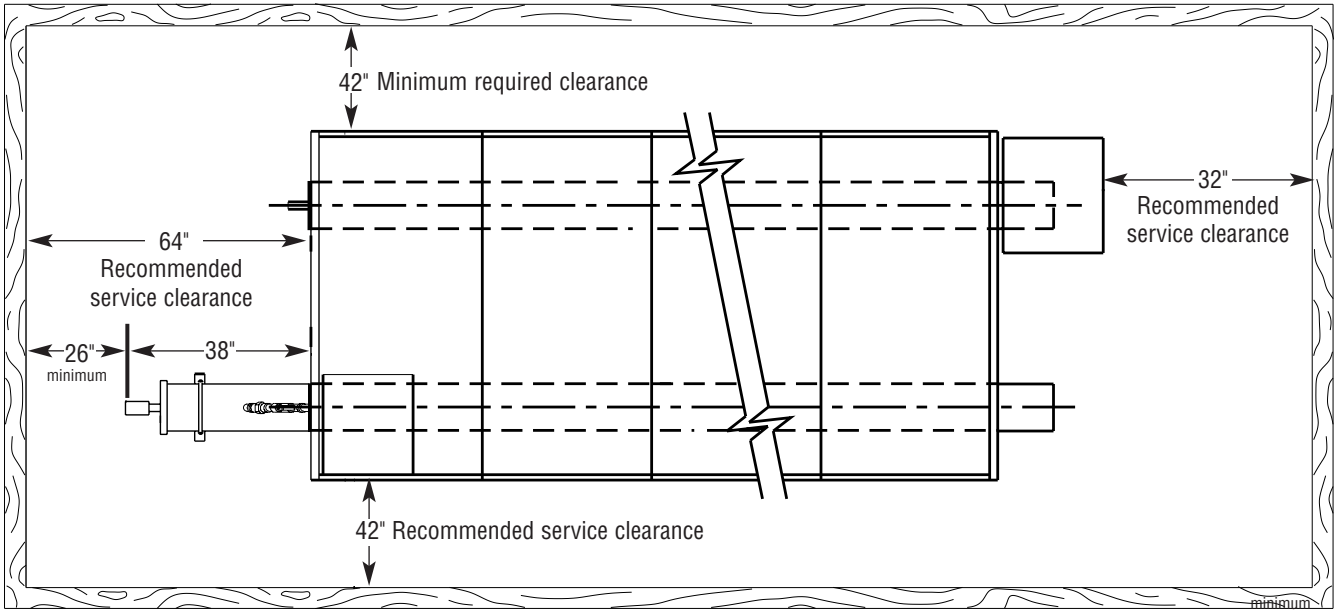

**Front Elevation**

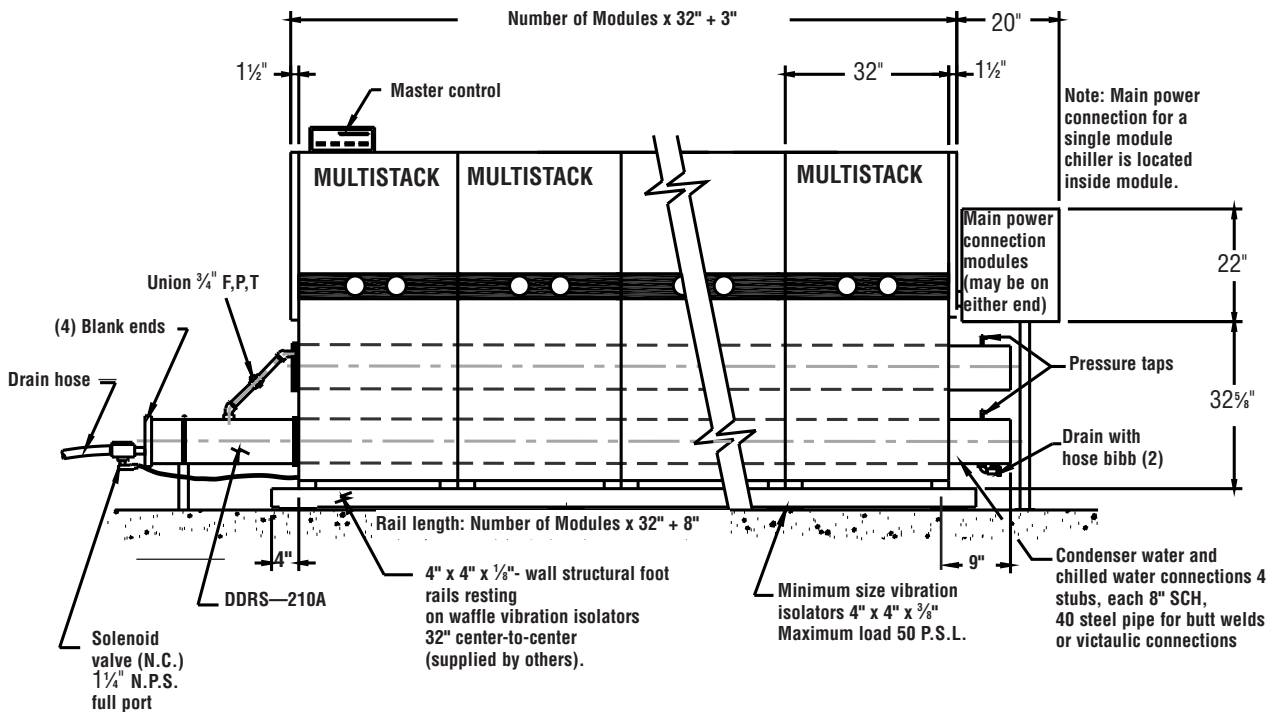

## **System Description**

Chiller shall incorporate two stage centrifugal Compressor with magnetic bearings and consist of single 80 ton refrigerant circuits. Each refrigerant circuit shall consist of an individual compressor, condenser, evaporator, electronic expansion valve, and control system. Each circuit shall be constructed to be independent of other circuits from a refrigeration and electrical standpoint. The chiller system must be able to produce chilled water even in the event of a failure of one or more refrigerant circuits. Circuits shall not contain more than 55 lb. of refrigerant.

## **General**

1. Chiller Modules shall be ETLc/US listed in accordance with UL Standard 1995, CSA Standard C22.2#236, and bear the ASME UM stamp on all heat exchangers.
2. Modules shall ship wired and charged with refrigerant. All modules shall be factory run tested prior to shipment.
3. Compressors, heat exchangers, piping and controls shall be mounted on a heavy gauge steel frame. Electrical controls, and associated components for each module shall be mounted within that module.

## **Chilled and Condenser Water Mains**

Each module shall include supply and return mains for both chilled and condenser water. Grooved end connections are provided for interconnection to eight inch standard (8.625 inch outside diameter) piping with Victaulic type couplings.

## **Evaporators and Condensers:**

Each evaporator and condenser shall be brazed plate heat exchangers constructed of 316 stainless steel; designed, tested, and stamped in accordance with ASME code for 300 psig working pressure on the evaporator and 360 psig working pressure on the condenser. Both the condenser and evaporator heat exchanger shall be mounted below the compressor, to eliminate the effect of migration of refrigerant to the cold evaporator with consequent liquid slugging on start-up.

## **Compressor**

1. Unit shall have a direct drive oil-free two-stage semi-hermetic centrifugal compressor complete with an active / passive magnetic bearing system. Casing shall be constructed from aluminum and shall not weigh more than 300 lbs each. The electronic soft starters, compressor controls, inverter power electronics, bearing and motor control shall be fully integrated into the compressor and shall be digitally controlled. The magnetic bearing system must be fully protected in the case of a power outage with its own inbuilt power generation system.

2. The impeller shall be statically and dynamically balanced. The compressor shall be vibration tested and not exceed a level of 0.14 IPS.
3. The capacity control should primarily be achieved by varying the compressors operating speed and a movable inlet guide vane shall only be used in the case of a surge or choke condition arising during normal operation. The moveable inlet guide vane shall be of the electro-mechanical type.
4. Bearing System: The compressor shall use an oil-free bearing system of the digitally controlled homo-pole magnetic bearing type. The bearings shall have a fully integrated back up bearing system and shall have a self generating power system so that the bearings shall be able to stay levitated in the case of a power failure. No sump heater is to be required. The bearing system shall use no more than 500 watts of energy during its normal operation and it must also have an auto balance capability in the case of any external vibration or out of balance event occurring.
5. Prime Mover: A direct drive synchronous permanent magnet brushless DC motor of the hermetic type of sufficient size to efficiently fulfill compressor horsepower requirements. Motor shall be liquid refrigerant cooled with internal thermal overload protection devices embedded in the winding of each phase
6. Motor Starter: The main motor starter is to be fully integrated into the compressor and shall be of the soft-start type with a maximum starting current of 20% of the full load current of the compressor. It must be fully integrated with the motors variable speed control system and it must be factory tested during the run test of the unit.
7. Variable Frequency Drive: The chiller shall be equipped with a fully integrated Variable Frequency Drive (VFD) to automatically regulate compressor speed in response to cooling load and compressor pressure lift. The chiller control shall coordinate compressor speed and guide vane position to optimize chiller efficiency.
  - a. digital regulator shall provide V/Hz control.
  - b. The VFD shall have 110% continuous overload of continuous amp rating with no time limit, PWM (pulse width modulated) output, IGBT (insulated gate bipolar transistors) power technology, full power rating at 2kHz, DC bus inductor (choke), and wireless construction. The inverter unit shall be refrigerant cooled and shall be fully integrated into the compressor package.

## **Central Control System**

1. Scheduling of the various compressors shall be performed by a microprocessor based control system (Master Controller). A new lead compressor is selected every 24 hours to assure even distribution of compressor run time.

2. The Master Controller shall monitor and report the following on each refrigeration system:
  - a. Discharge Pressure Fault
  - b. Suction Pressure Fault
  - c. Compressor Winding Temperature
  - d. Suction Temperature
  - e. Evaporator Leaving Chilled Water Temp.
3. The Master Controller shall monitor and report the following system parameters:
  - a. Chilled Water Entering and Leaving Temperature
  - b. Condenser Water Entering and Leaving Temperature
  - c. Chilled Water and Condenser Water Flow
4. An out of tolerance indication from these controls or sensors shall cause a fault indication at the Master Controller and shutdown of that compressor with the transfer of load requirements to the next available compressor. In the case of a System Fault, the entire chiller will be shut down. When a fault occurs, the Master Controller shall record conditions at the time of the fault and store the data for recall. This information shall be capable of being recalled through the keypad of the Master Controller and displayed on the Master Controller's 2 line by 40 character back-lit LCD. A history of faults shall be maintained including date and time of day of each fault (up to the last 20 occurrences).
5. Individual monitoring of leaving chilled water temperatures from each refrigeration system shall be programmed to protect against freeze-up.
6. The control system shall monitor entering and leaving chilled water temperatures to determine system load and select the number of compressor circuits required to operate. Response times and set points shall be adjustable. The system shall provide for variable time between compressor sequencing and temperature sensing, so as to fine tune the chiller to different existing building conditions.
7. Each module shall have a dedicated sub-controller and hand-off/auto switch such that in the event of loss of communications with the master controller, each module is capable of operating independently to meet chilled water load.

### **Power Connections**

Chiller shall have a single point power connection and external inputs and outputs to be compatible with the building management system. Inputs/Outputs include:

1. Remote Start/Stop
2. Cooling Alarm

Additionally, chiller shall be integrateable with building management systems through BacNet®, ModBus®, N2, or LON.

### **Inlet Headers**

Each inlet header shall incorporate a built in 30-mesh in-line strainer system to prevent heat exchanger fouling. This system shall include an automatic self-cleaning debris blow down system (MultiFlush™) for on-line cleaning of the in-line strainers.

### **Master Controller**

Stages and monitors the status of up to 8 modules. Provides interface with all system variables and set points.

### **LCD Display**

4X20 character backlit LCD displays system and chiller variables. A complete picture of both compressor and chiller system performance is available at the display. This includes but is not limited to refrigerant temperatures and pressures, water temperatures, compressor speeds (actual and desired), detailed fault information, compressor run hours, and theoretical system capacity.



### **System Interface Portal**

Integrates chiller with building management system through BacNet®, ModBus®, N2, or LON.

### **Module Controller and Hand-Off/Auto Control**

Receives direction from the master controller and provides the capability of standalone operation if the master controller fails or if communication with the master controller is lost. Each module controller communicates directly with its module's MagLev™ compressor through ModBus® providing a more redundant means of multiple compressor control.



**MULTISTACK WATER COOLED CENTRIFUGAL  
COMPRESSOR**

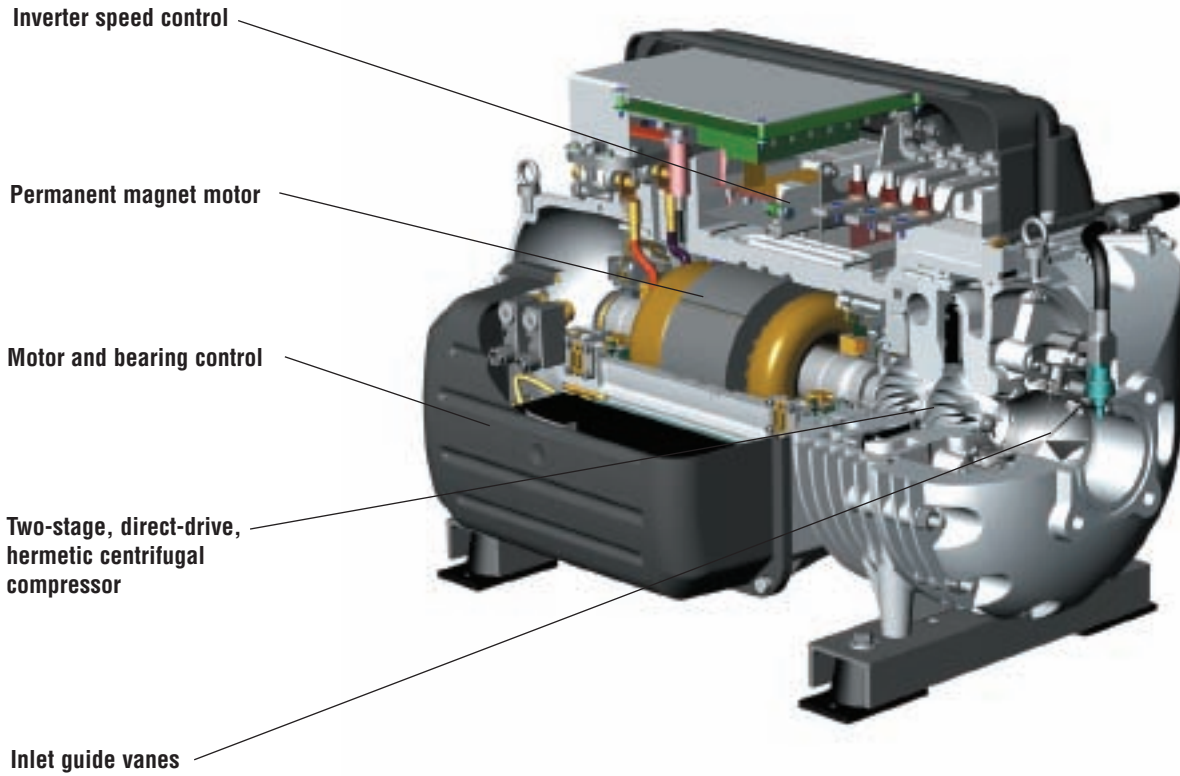

1065 Maple Avenue  
P.O. Box 510  
Sparta, WI 54656

Phone 608-366-2400  
Fax 608-366-2450

***The Leader in Modular Chillers***